

Kai Hung Machinery

Company Introduce



KAI HUNG MACHINERY CO., LTD.

Feedback Win-Win with you!!

Tel : 886-6-203-5558 Email : sales-02@kaihung.com

<http://www.kaihung.com>

Basic Information

- ④ Founder: MING-TA, LEE
- ④ Headquarter – Kai Hung Machinery Co. Ltd.



Established : 1991
Capital : 1 Million (USD)
Area of firm : 8,000m²
Number of Employee : 65

- ④ Services Distributor –
Kai Hung Machinery Co. Ltd.(Jia Shan)



Established : 2008

- ④ China Branch –
Kai Qi Intelligent Machinery Co. Ltd.(Jia Xing)



Established : Oct.,2017
Number of Employee : 15

Development Milestone

凱泓機械股份有限公司



2001

- Whole Plant Automation Production Line for Brushless Motor . (The First Equipment)

2003

- Launch - Hydraulic (Horizontal / Trunnion) Rotary Transfer Machine.

2012

- Launch - Full Servo NC Rotary Transfer Machine.

2014

- Relocation YongKang Technology Industrial Park – Into the Vehicle Industrial Processing Machine Manufacturing.

2015

- Machine with CCD Vision Recognize Automatic System and Online Automatic Measurement System..
- Patent – The rotary transfer structure of multi-spindles rotary transfer machine.....

2016

- Whole Plant Automation Production Line for Brushless Motor which selling it to 20 set Equipment.(Since 2001)

2017

- China Branch - Kai Qi Intelligent Machinery Co. Ltd
- Launch - All-purpose NC (Horizontal / Trunnion) Rotary Transfer Machine.
- Patent – The magnet implanting device and method of rotor.

2018

- Patent – Armature shaft and lamination core assembly machine and resisting alloy method.

Marketing Countries

Asia-Taiwan	Asia -China	Asia -Others	America	Europe	Africa
46%	38%	8%	3%	3%	2%

Kai Hung Cultivate quality technical team, creating the excellent reports in the **Asian market**.

Entering America, Europe and Africa to serve customers in various regions.

The sales aspect, received enthusiastic response from customers to achieve effective market share expansion



Production Line	6%
Multi-spindles Rotary Transfer Machine	34%
Two-way Processing Machine	14%
Motor Production Equipment	24%
Others Machine	22%

(Analyze by selling the machine ~ 2018)
Source : Kai Hung

Business Scope

凱泓機械股份有限公司



Production Line



Multi-spindles Rotary Transfer Machine
(Trunnion / Horizontal)



Two-way Processing Machine
(Two-way 、 Aluminum Tube 、 Cylinder Rolling)



Motor Production Equipment
(Rotor 、 Stator 、 Assembly Line)



Others Machine

**Customized
Equipment**

Equipment

凱泓機械股份有限公司

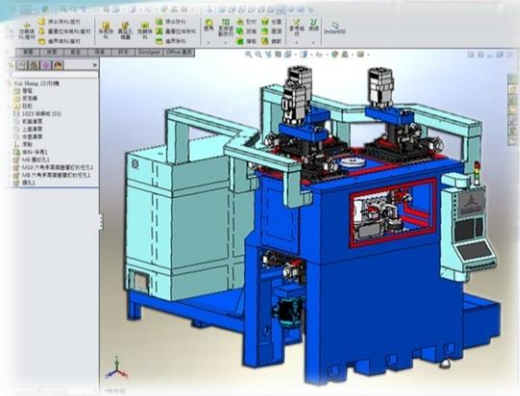

Keep improving and developing. Pursuit of perfect work presentation. Manufacture general type special purpose machine.

We use **SolidWorks 3D CAD** software to keep the accuracy and stability of machine.

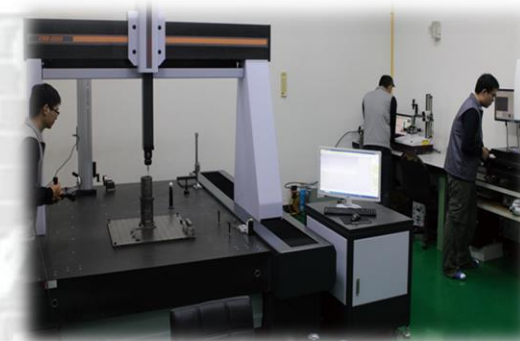

Coordinate Measuring Machine –
Precision measuring equipment ensures our parts and assembling quality.



Precision Assembly Workshop-
The shop equips with air conditioner to keep precision of spindles and component assembling.

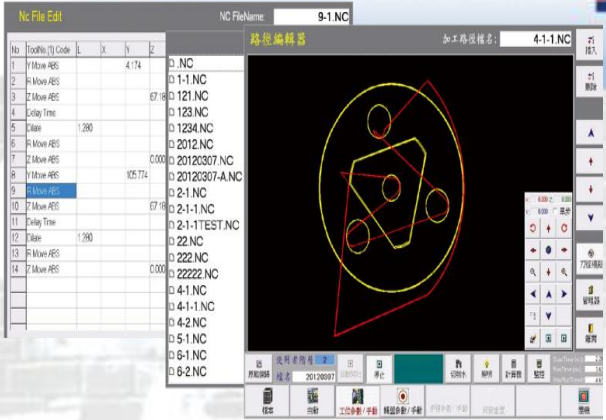

Graphic touch interface and composite dialogue design (bilingual supported). Easier manipulation for quick introduction to the production line.

Button-type dialogue input with relevant path displayed to quickly complete the accurate editing of machining program.

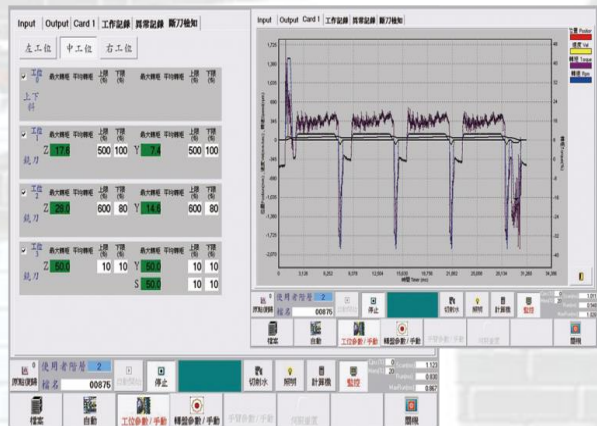

Tooling Broken Management System sets the times of tool processing and tool prediction the life-time.

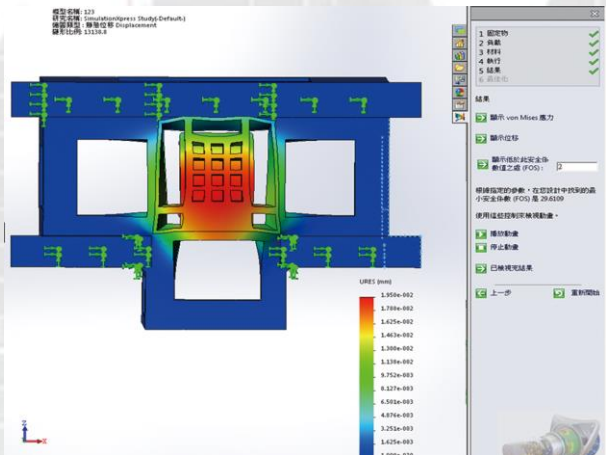

Stress Analysis of Machine Body.

Industry Application

Application / Material	Aluminum	Steel	Brass
Sanitary Ware	0	0	<u>4</u>
Valve	<u>1</u>	<u>4</u>	<u>12</u>
Automobile Parts	<u>5</u>	<u>13</u>	0
Pneumatic Cylinder	<u>9</u>	0	<u>1</u>
Others	<u>1</u>	<u>5</u>	0



Sanitary Ware

Valve

Automobile Parts

Pneumatic Cylinder

Others

Product :

Engine Piston Production Line

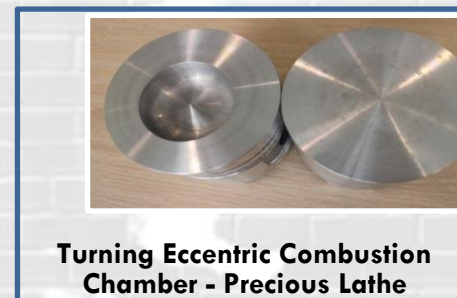

Product :

Flexible Manufacturing System

凱泓機械股份有限公司

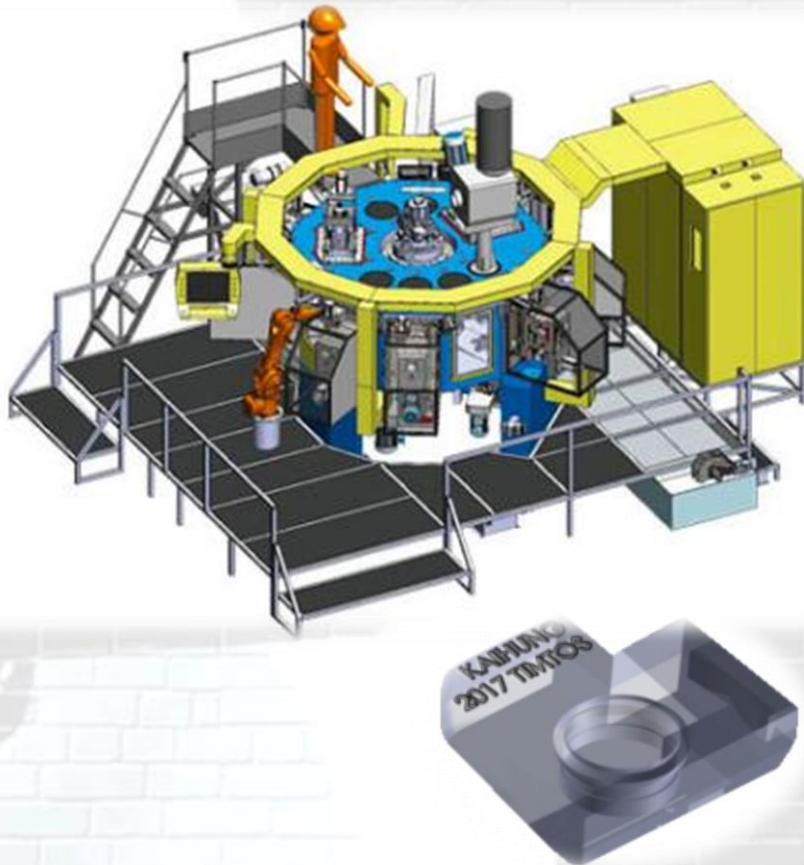

* Automatic Integration

The automatic manufacturing systems is for integration of multiple CNC lathes, six axes manipulators and multi-spindles machines of Kaihung .

* CCD Vision Recognize System

Using the CCD Vision Recognize workpiece contour informs the manipulator to pick up the workpiece in any different position and angle.

* Laser Engraving

With the laser engraving machine to engrave the serial number on the workpiece.

* Automatic Measuring

With a linear gauge to measure the hole depth automatically , also equip with OK/NG classification.

Production Line

Multi-spindles Rotary
Transfer Machine

Two-way Processing
Machine

Motor Production
Equipment

Others Machine

Product :

Multi-spindles (Horizontal) Rotary Transfer Machine

凱泓機械股份有限公司



Servo or Hydraulic

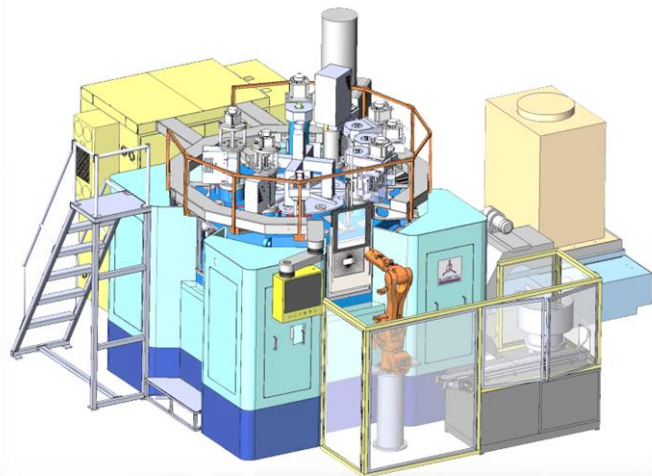

@ High efficiency production

- Multi-spindles : each spindle can be matched with XYZ servo slide.
- Multi-stations : each stations can be set 3 spindles simultaneous processing.
- It can realize 8 to 15 times capacity of general central processing machine and CNC lathe.

@ Flexible Manufacturing

- The control software can edit the machining program.
- It can equip with zero fixture which shorten the fixture exchange time and saving changeover time.
- The spindle can be matched with XYZ servo slide and C Axis angle control.



- * Workpiece: BIT ADAPTER
- * Material: SUS304
- * There are punched/hexagonal holes in the process
- * Specified angle drilling function
- * Processing time : about 10sec.±10% / pcs

Production Line

Multi-spindles Rotary Transfer Machine

Two-way Processing Machine

Motor Production Equipment

Others Machine

Product :

Multi-spindles (Horizontal) Rotary Transfer Machine

凱泓機械股份有限公司



Servo or Hydraulic



- * Workpiece: water meter
- * Material: brass
- * Features:
 - Special fixture design to stabilize the clamping of shaped workpieces.
 - The hydraulic drive spindle has high stability.
 - High-efficiency multi-station simultaneous processing.

Product :

Multi-spindles (Trunnion) Rotary Transfer Machine

凱泓機械股份有限公司



Servo OR Hydraulic

- ② The machine is specially designed for the machining of tri-direction center holes.
- ② Each spindle is provided with dialogue-type program editing function to carry out boring, tapping and groove cutting functions.



- * Workpiece: Automotive parts (Hydraulic tappet)
- * Material: carbon steel
- * Features:
 - Full servo control, easy to adjust processing parameters, improve production efficiency.
 - High-efficiency multi-station simultaneous processing.
 - No secondary positioning problem, high precision and high stability.
 - With feed tray, manipulator, positioning fixture.
 - With coolant thru spindle to improve tool life.

Production Line

Multi-spindles Rotary Transfer Machine

Two-way Processing Machine

Motor Production Equipment

Others Machine

Product :

Multi-spindles (Trunnion) Rotary Transfer Machine

凱泓機械股份有限公司



Servo or **Hydraulic**

- * Workpiece: Cut-out valve (1/2", 5/8")
- * C/T : approx. 8 sec. $\pm 10\%$ / pcs
- * Material: brass
- * Features:
 - The hydraulic drive spindle has high stability.
 - High-efficiency multi-station simultaneous processing.



Production Line

Multi-spindles Rotary Transfer Machine

Two-way Processing Machine

Motor Production Equipment

Others Machine

Product :

Two-way Processing Machine

凱泓機械股份有限公司



- * Workpiece: Aluminum Die Casting (hand tool)
- * C/T : approx. 12 sec. \pm 10% / pcs
- * Material: Aluminum
- * Features:
 - Drilling/tapping finish at once and saving time.
 - The left and right spindles are processing simultaneously to ensure positional tolerance requirements.
 - The shaped fixture is designed to ensure clamping stability.



Production Line

Multi-spindles Rotary
Transfer Machine

Two-way Processing
Machine

Motor Production
Equipment

Others Machine

Product :

Pipe Fitting Machine

凱泓機械股份有限公司



- * Workpiece: cylinder fittings
- * C/T : approx. 12 sec. $\pm 10\%$ / pcs
- * Material: Aluminum extrusion
- * Features:
 - Large processing range - $\varnothing 16 \sim \varnothing 100/L80-L2000$
 - The processing by end face machining, chamfering and tapping.
 - Compared with the traditional machine, the equipment has the lowest cost and easy to ensure the parallelism of the end face.



Production Line

Multi-spindles Rotary
Transfer Machine

Two-way Processing
Machine

Motor Production
Equipment

Others Machine

Product :

Cylinder Rolling Machine

- ⊗ Cylinder head/tail cap is synchronous rolling at once.
- ⊗ Adopting the same movement design of the back and front of the chuck (avoiding angular deviation)
- ⊗ Quickly jig exchange to save time for changing workpieces of different sizes.

- * Program simulation tool path
- * Travel range: 6mm~63mm
- * Diameter range: 5mm~1000mm

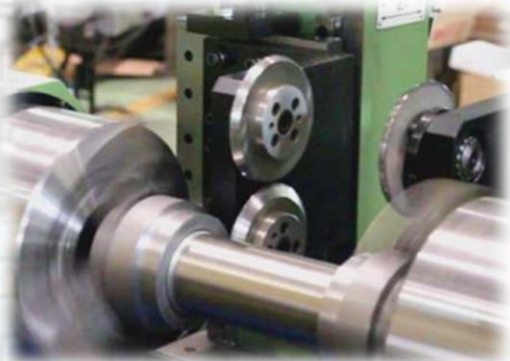

Product :

Assembly Line

凱泓機械股份有限公司



- * Dust Cleaning the Stator and the Internal Body.
- * Place In Wave Washer.
- * Inspect Washer Thickness.
- * Auto Screw Tightening Station.
- * Testing Axial Clearance Length.
- * Testing Three-phase Voltage Terminal.
- * Inspect Screw Tighten Torque.
- * Using the Bar Code to Distinguish Workpiece.



Production Line

Multi-spindles Rotary
Transfer Machine

Two-way Processing
Machine

Motor Production
Equipment

Others Machine

Product :

Rotor Shaft Processing Machine

凱泓機械股份有限公司



- * Tower type storage for lamination.
- * Feed magnet by bowl feeder and height measurement.
- * Automatic lamination thickness detection, glue instillation, laser engraving, assembly the magnet, hardening heating and testing operations.
- * Cooling zone after hardening.
- * The lamination of phase angle positioning, pull-off force test, dimension measuring.
- * Real time monitor shaft press fit position and force.
- * Shaft series No. detection.



Production Line

Multi-spindles Rotary
Transfer Machine

Two-way Processing
Machine

Motor Production
Equipment

Others Machine

Product :

Stator Epoxy Instillation and Hot-air Drying Oven

凱泓機械股份有限公司



Epoxy Instillation and Hot-air Drying / Hot-air Drying

- * There are divided into preheat, drip, hardening heating and cooling zone, the heating temperature reach up to 250 °C.
- * The basket bench can be mass production which go with auto loading and unloading by manipulator .
- * With safety feature to prevent overheat, protect circuit, exhaust system, explosion proof and prevent staff scald.
- * Customized machine, base on process parameters and capacity requirement.



Production Line

Multi-spindles Rotary
Transfer Machine

Two-way Processing
Machine

Motor Production
Equipment

Others Machine

Product :

Hot Air Drying Oven

凱泓機械股份有限公司



Epoxy Instillation and Hot-air Drying / Hot-air Drying

- * To dry the glue after the stator press-in the case.
The front side is loading area, and the rear side is unloading area.
- * The heating and cooling time is based on customer's requirement.
- * This machine equip with 6-point temperature recorder to make the temperature is available to monitor and adjust.
- * Using multi-protective device. As one unit is fault function, other protective devices will prevent continuous failure.
- * Heavy duty structure and high quality control unit to suit for 24 hours a day, 7 days a week working.



Production Line

Multi-spindles Rotary
Transfer Machine

Two-way Processing
Machine

Motor Production
Equipment

Others Machine

Product :

Magnet Insert Into Rotor-core Lamination

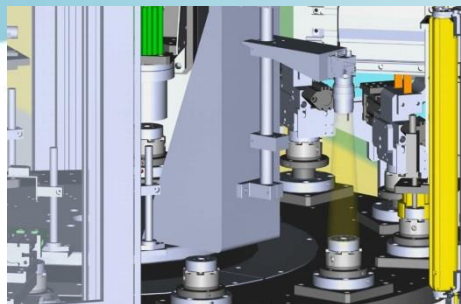

CCD Detection Module
Number

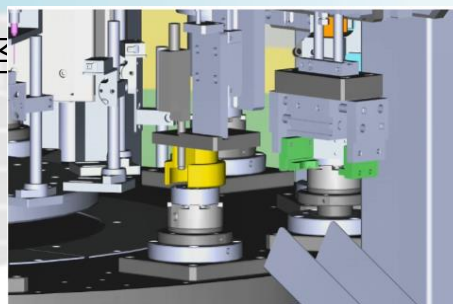

Height Detector -
Rotor Height Measurement

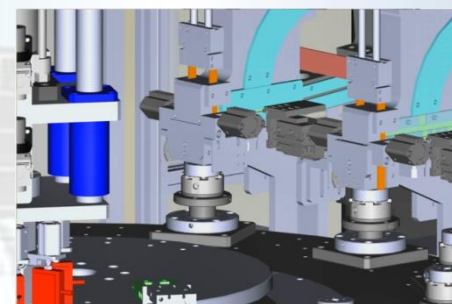

Insert the Magnet

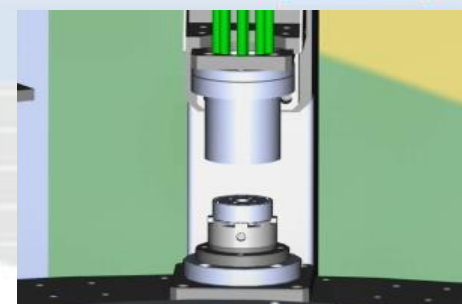

Detecting the Amount
of Magnets

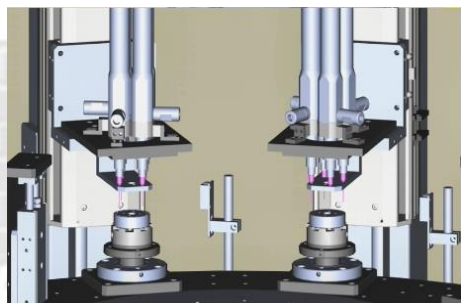

Gluing Instillation

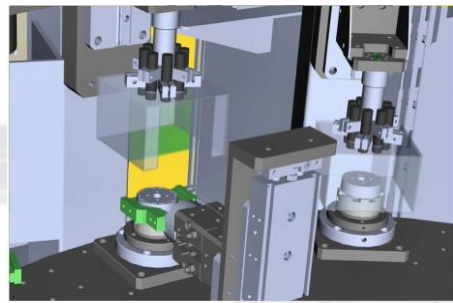

UV Light Hardening Station

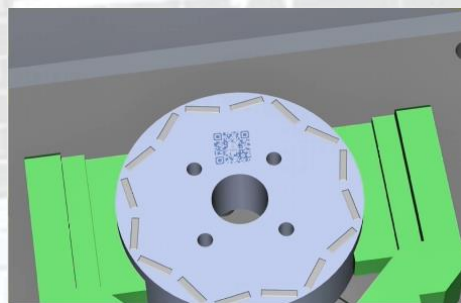

Laser Engraving

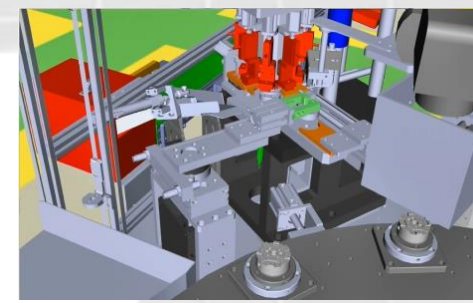

Pull-off Force Testing

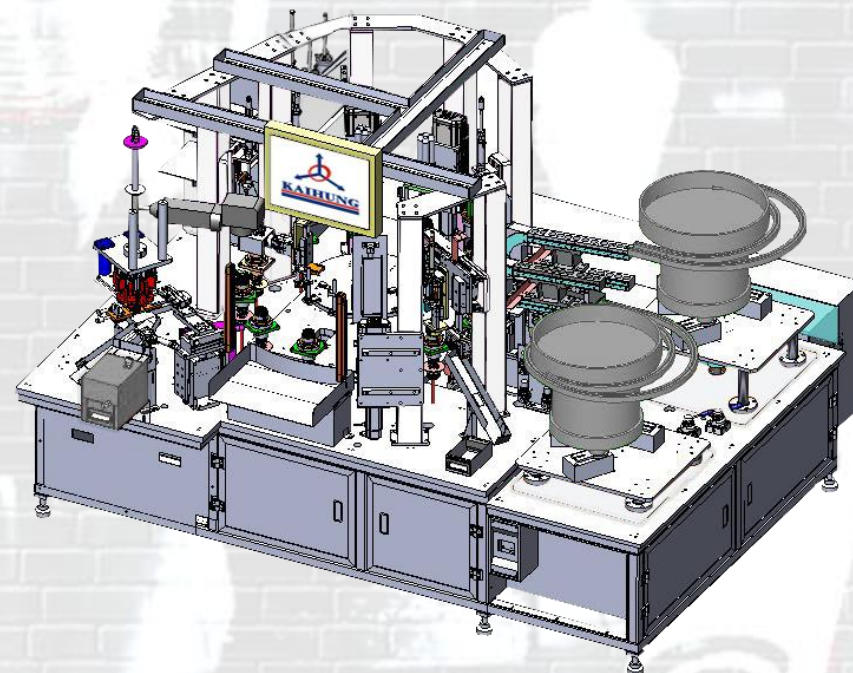

Motor Production
Equipment

Product :

Full-process Servo Assembling Press Machine

- * 1T,3T,5T Apply to press and assembling precisely.
- * It can set the process of pressing in manually.
- * Read each dimension of pressure value by load cell, transfer to pressure curve, and it can be recorded by daily, weekly, monthly.



Production Line

Multi-spindles Rotary
Transfer Machine

Two-way Processing
Machine

Motor Production
Equipment

Others Machine

Product :

Others Machine

凱泓機械股份有限公司



Pressing Machine



Chamfering Machine



Drilling Machine



Grinding Machine



Riveting Joint Equipment



Bar Straightening Machine

Production Line

Multi-spindles Rotary Transfer Machine

Two-way Processing Machine

Motor Production Equipment

Others Machine

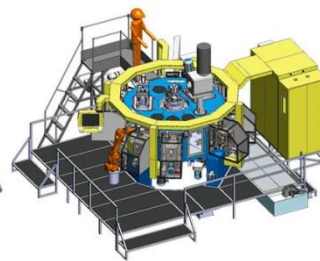
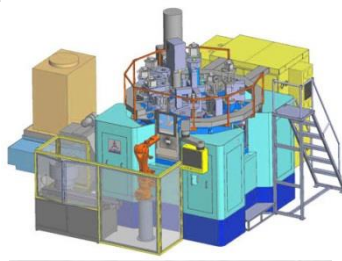

凱泓機械股份有限公司(總公司)

KAI HUNG MACHINERY CO.,LTD.

台南市永康區永科七路75號(永康科技工業區)

No.75 Yongke 7th RD.,YongKang Dist.,

Tainan City,71041,Taiwan

(YongKang Technology Industrial Park)

Tel:886-6-203-5558

Fax: 886-6-203-2555

E-mail: sales-02@kaihung.com

嘉興凱騏智能機械有限公司(分公司)

314500 浙江省嘉興市桐鄉市經濟開發區同仁路635號

嘉興服務處：TEL: 0573-88081659

FAX: 0573-88081653

廣州服務處：TEL: 020-86382330

FAX: 020-86382320

廈門服務處：TEL: 0592-5282520

FAX: 0592-5144795



凱泓機械股份有限公司