

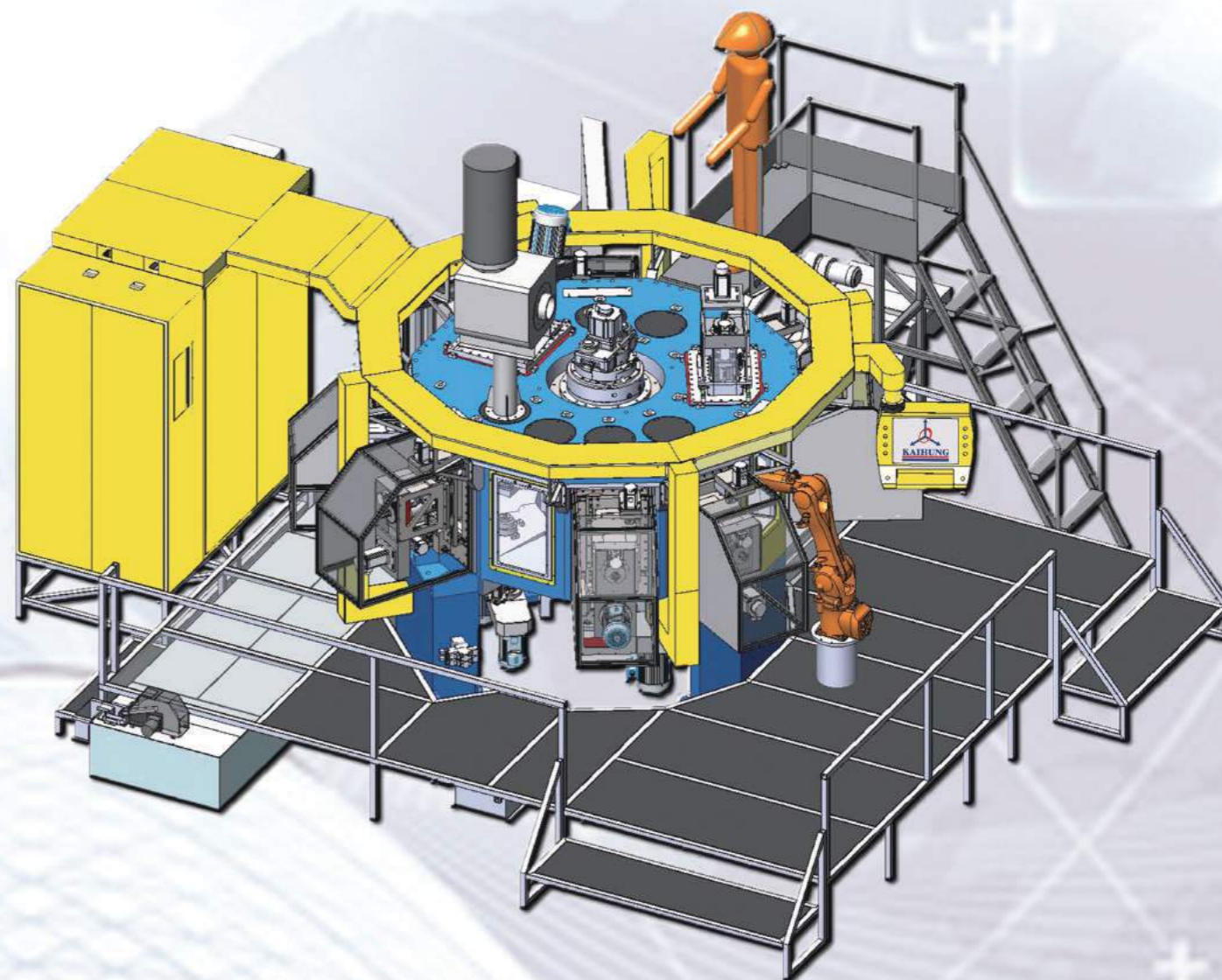

凱泓機械股份有限公司
KAI HUNG MACHINERY CO., LTD.



凱泓機械股份有限公司

KAI HUNG MACHINERY CO., LTD.

71041 台南市永康區永科七路 75 號 (永康科技工業區)
No. 75 Yongke 7th RD., YongKang Dist., Tainan City, 71041, Taiwan
(YongKang Technology Industrial Park)

Tel: 886-6-203-5558

Fax: 886-6-203-2555

E-mail: sales-02@kaihung.com <http://www.kaihung.com>

嘉興凱騏智能機械股份有限公司

JIA XING KAI QI INTELLIGENT MACHINERY CO., LTD.

314500 浙江省桐鄉市經濟開發區同仁路 635 號
No. 635 Tongren Road, Tongxiang City, Jiaying City, Zhejiang Province

Tel: +86-573-8808-1659

Fax: +86-573-8808-1653

E-mail: jskh@kaihung.com

廈門服務處: TEL: 0592-5282520

FAX: 0592-5144795

專機與泛用機:

CNC多軸轉盤加工中心機、轉盤 / 水車多軸加工機

CNC Multi-spindles Rotary Transfer Machine

Horizontal / Trunnion Rotary Transfer Machine





公司簡介

凱泓機械成立於1991年，從事CNC多軸轉盤/水車多軸加工機、自動組立裝配流水線、五金閥門燃氣閥/潔具加工客製設備、汽機車零件自動化生產線等。隨著大陸市場發展，2007年成立分公司，2017年遷入浙江省桐鄉市。

研發PC Based多軸控制器，性能媲美國際大廠，並導入CCD視覺辨識、傾斜主軸等技術。依顧客需求，設計獨一無二之機台，達到最大的績效。

凱泓機械秉持「創造績效、共創雙贏」。三大核心價值：時時以顧客角度思考、做好每項服務以維繫優良品質、主動提升新式技術，達到企業長期發展策略。

二十多年來，在同仁齊心努力下共同奮鬥吸取各方面資訊並研討論開發，在自動化機械工業界漸漸打出一片天下，目前銷售市場遍及世界各國。

2001年 無刷馬達整廠自動化生產線(第一條)。

2003年 發表油壓(臥式/立式)轉盤加工機。

2010年 發表NC(立式/臥式)轉盤加工機。

2012年 發表全伺服NC轉盤加工機。

2014年 遷至台南永科廠 - 跨入車輛工業加工機製造。

2015年 導入CCD視覺辨識及線上自動量測系統。

2016年 銷售無刷馬達生產線達到20條。

2017年 發表泛用型NC多軸加工機。

Company Introduction

Kai Hung was founded in 1991, and specializes in the design and manufacturing of CNC multi-spindles trunnion/ horizontal rotary transfer machine, automatic assembly stream line, customized equipment of valve/sanitary/gas parts processing, automation production line for automobile parts. With the China's market development, China Branch was established in 2007 and moved in Tongxiang City in 2017.

Developing the PC Based multi-spindles controller, Kai Hung's performance is comparable to other international brands which technology with CCD vision recognize automatic system, spindle tilt and so on. According to customer demand, Kaihung designs unique machinery and achieves maximum performance.

Kaihung insists on "To create a performance and create a win-win situation". The core values is efforts to develop the ability to self-developed, doing every service to maintain good quality, taking the initiative to enhance the new technology, achieving the business long-term development strategy.

Over the 2 decades, we have gradually established our reputation in the automatic machinery industry thanks to diligent work from our colleagues, who have absorbed comprehensive information to facilitate product R&D. Our markets are spread across different countries around the globe.

2001 Whole Plant Automation Production Line for brushless motor (The first equipment).

2003 Launch - Hydraulic (horizontal / trunnion) Rotary Transfer Machine.

2010 Launch - NC (horizontal / trunnion) Rotary Transfer Machine.

2012 Launch - Full Servo NC Rotary Transfer Machine.

2014 Relocation YongKang Technology Industrial Park. Into the vehicle industrial processing machine manufacturing.

2015 Machine with CCD Vision Recognize Automatic System and Online Automatic Measurement System.

2016 Whole Plant Automation Production Line for brushless motor which selling it to 20 sets of equipment.

2017 Launch - All-purpose NC (horizontal / trunnion) Rotary Transfer Machine.

產品類別 Product Class

CNC多軸轉盤加工機
CNC Multi-spindles Horizontal Rotary Transfer Machine

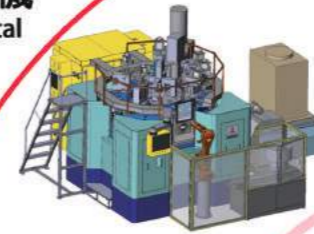

CNC水車多軸加工機
CNC Multi-spindles Trunnion Rotary Transfer Machine

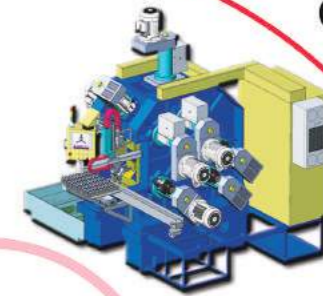

彈性製造系統
Flexible Manufacturing System



多工、多軸、多樣性、共用性、自動化

泛用專用機
All - Purpose Machine

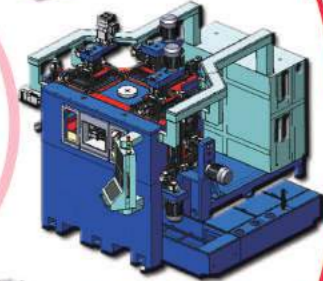

自動組立裝配流水線
Automatic Assembly Stream Line



監控、檢測、壓入
Monitor、Detection、Press



客製化服務 Customized Services

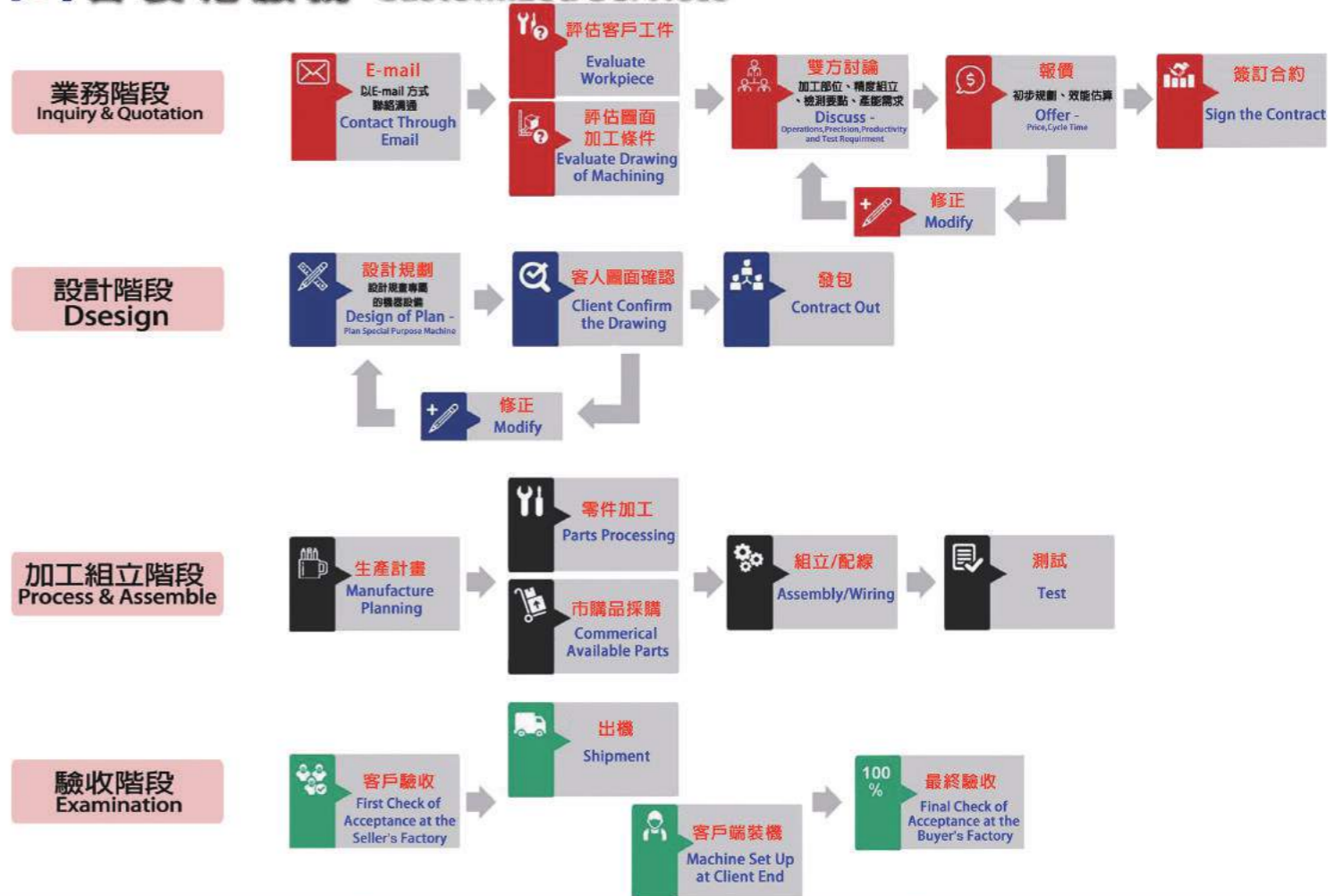

CNC 多軸轉盤加工中心機 CNC Multi-spindles Rotary Horizontal Machining Center

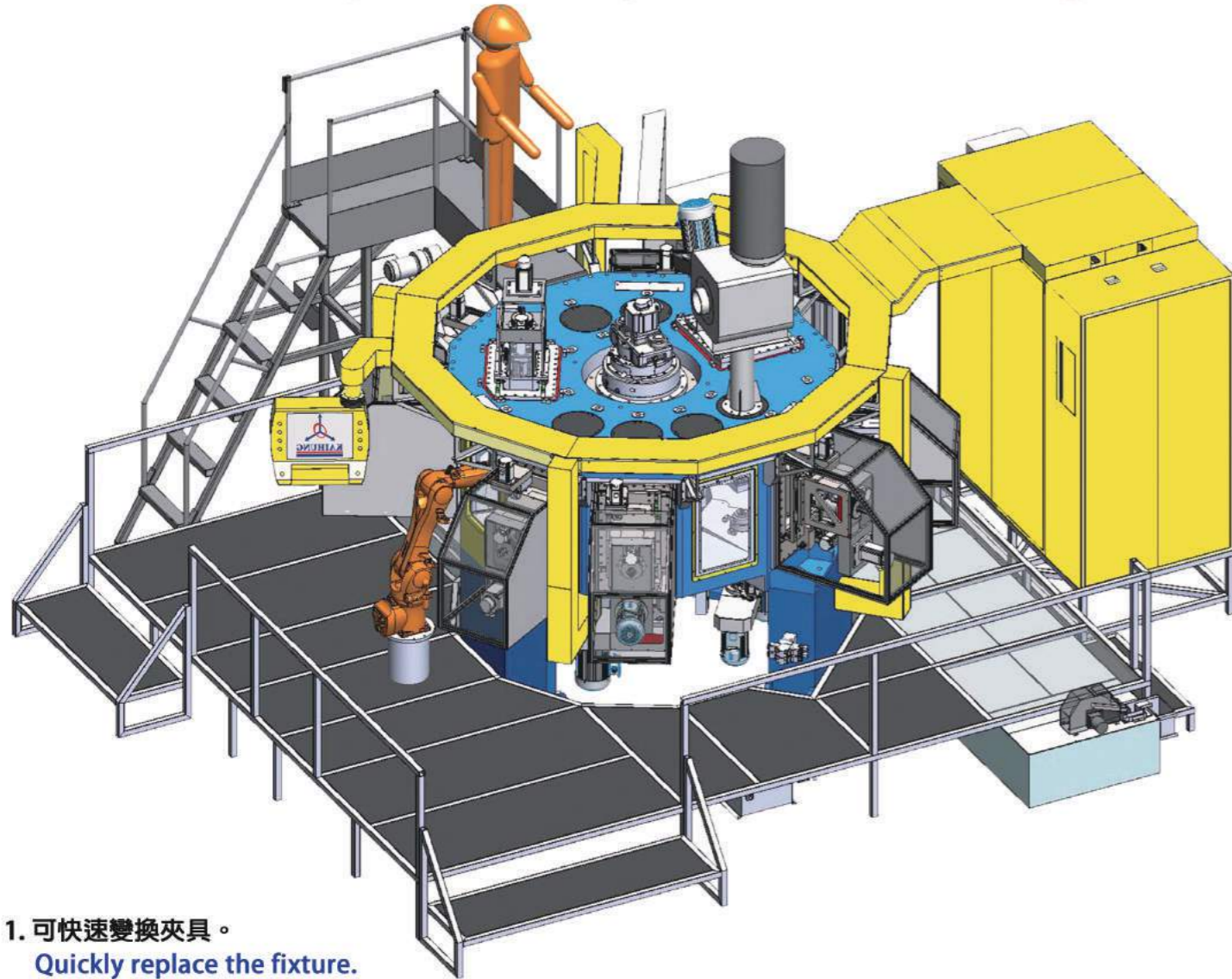

1. 可快速變換夾具。
Quickly replace the fixture.
2. 每一軸有伺服滑台。
Each spindle has servo slide.
3. 依加工尺寸，自行編輯程式。
According to the processing size, self-editor program.
4. 各軸可做攻牙、銑牙、鑽孔、搪孔、異形孔、曲線、圓弧槽。
Each spindle can do tapping, threading milling, drilling, boring, special shape hole, curve, arc groove.
5. 適合少量多樣產品。
Suitable for small-volume production of a wide range of different items.

工位 (Station)	最多主軸數 - 每一主軸數可搭配 X、Y、Z 滑台 (Maximum number of spindles - Each spindle can use X-Y-Z slide)	上 (Up)	側 (Side)	下 (Down)
4	9	3	3	3
6	10	3	4	3
8	13	4	5	4
9	14	4	6	4
12	20	6	8	6

機台上裝設斷刀偵測系統，監測刀具磨損狀態，減少刀具損失，提高產品良率。設備部分，隨時掌握機台狀況，預先規劃保養時程，避免非預期當機而影響生產。因應客戶需求，整合工業4.0以增進企業競爭力並提高生產價值。

The machine is equipped with tool-breaking detection system to monitor the tool wearing status and reduce the loss of tools while improving the defect-free rate. For equipment, grasping the status of the machine at any time and pre-planning maintenance schedule to avoid the unexpected crash and affect production. With customer requirement, the integration of industry 4.0 to promote the competitiveness of enterprises and increase production value.

規格 Specification

主軸規格	Spindle	Unit				
軸管直徑	Spindle Sleeve Diameter	mm	-	Ø60	Ø80	Ø120
主軸轉速	Spindle Speed	rpm	標準型 (Standard Type)	8000	2800	2200
			高速型 (High Speed Type)	X	6000	4000
刀柄尺寸	Shank Size	type	-	ER25	NT30	NT40
滑台行程		Slide Table Stroke	Unit			
X/Y 軸行程	Axis - X/Y Table Stroke	mm	60x60, 120x120, 200x200, 250x250			
X/Y 軸最高位移速度	Axis - X/Y Maximum Displacement Speed	m/min	30			
Z 軸行程	Axis - Z Table Stroke	mm	120			
Z 軸最高位移速度	Axis - Z Maximum Displacement Speed	m/min	15			
轉盤分度		Rotary Indexing	Unit			
驅動方式	Kind of Drive	-	伺服馬達 (Servo Motor)			
重複精度	Repeatability Accuracy	-	4 秒內 (Within 4 Sec.)			
夾具	Fixture	-	油壓 (Hydraulic)	同步夾爪 (Sync Jaws) 單向夾爪 (One-way Jaws)		
其他		Other	Unit			
電控箱冷氣恆溫	Electrical Control Box Air Conditioning Thermostat	°C	25°C~30°C			

選擇配備	Optional Accessories			
控制器	Controller	歐系	European	BECKHOFF
		台系	Taiwan	Kai Hung (PC Based)
伺服馬達 (X,Y,Z)	Servo Motor (X,Y,Z)	歐系	European	BECKHOFF
		台系	Taiwan	台達(Delta)
多軸器	Multi-axis			
主軸傾斜	Spindle Inclination			
中心出水主軸	Through Spindle Coolant System			
快速換模 (Zero Point)	Quickly replace the modular jig (Zero Point)			
穩壓器	Voltage Regulator			
油水分離	Oil Extractor			
高壓中心出水	Coolant Through Spindle, CTS			
切削液恆溫設備	Cutting Fluid Thermostatic Equipment			

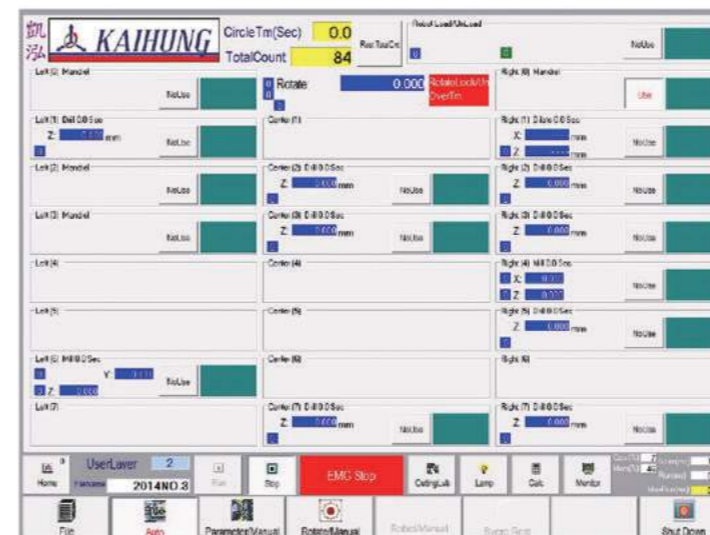
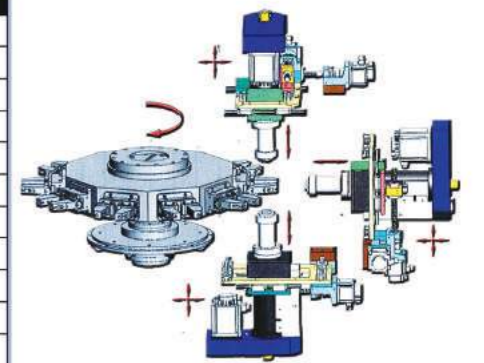

控制器 - PC Based (凱泓自行研發)
Controller - PC Based (Kai Hung developed system)

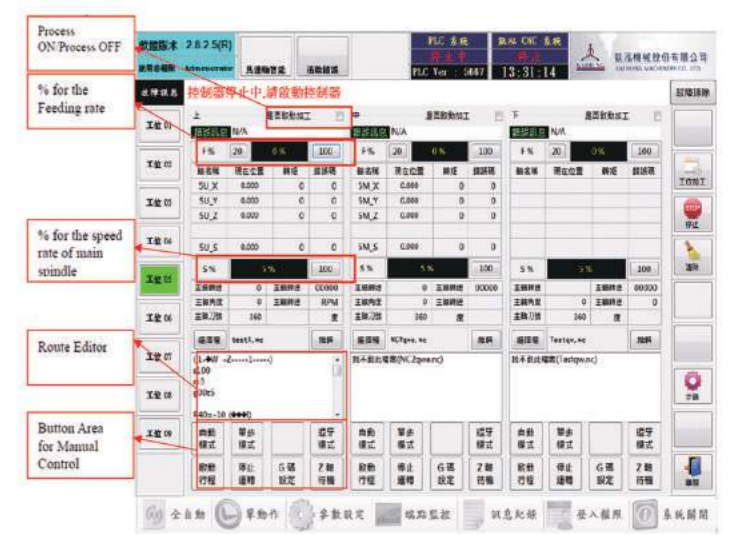

控制器 - BECKHOFF
Controller - BECKHOFF



8工位CNC多軸轉盤加工機

8 Stations CNC Horizontal Rotary Transfer Machine

3D多軸複合加工機為“臥式轉盤”，以0°、90°、180°三方向同時加工，每一軸可任意編輯程式，一台設備等於多台中心加工機、數控車床8倍~20倍的產能，提高生產效能，節省機台加工產生的成本。

This 3D multi-spindle complex machining center is "Horizontal Rotary". It allows 0°, 90° and 180° tri-directional machining. Each spindle allows program editing whenever required. Each piece of equipment conglomerates the capacity of several units of machining centers into one unit in which the numerically controlled lathe can yield 8 to 20 times the productivity. Improve production efficiency, saving the machine processing costs.

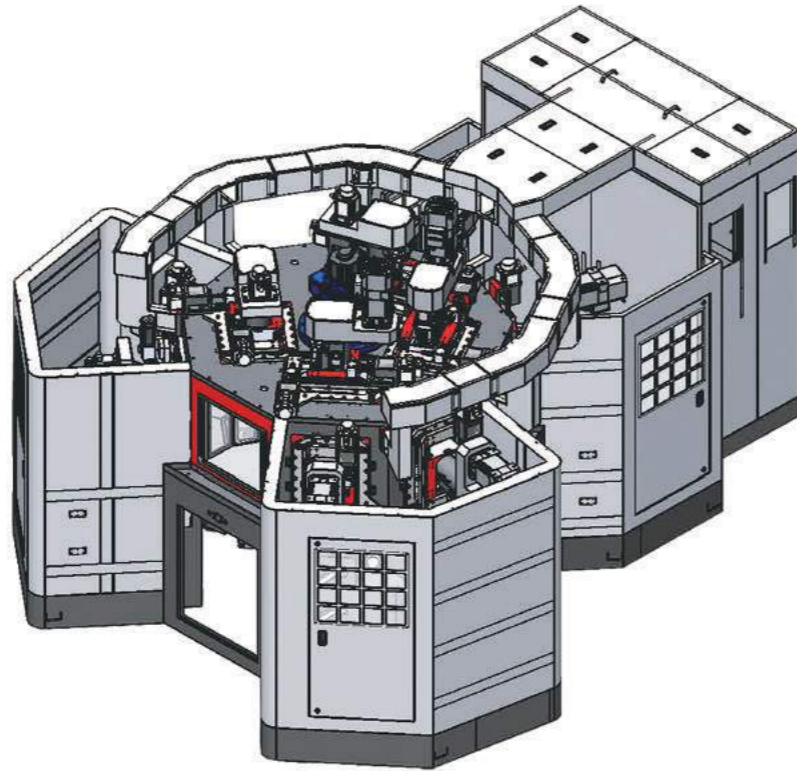

同步夾具、高強度、高精密提高工件加工後的對稱度
Synchronous clamp moving, higher strength and higher precision, all contributing to accurate symmetry of the workpiece after being processed



治具盤面易於更換、夾持治具快速定位，
面盤直徑φ1500 / 平面度0.02
Easier clamp disc replacement, more accurate clamping and faster positioning
Disc Diameter : 1,500mm / Plane Tolerance : 0.02



上、中、下伺服滑台同步加工
Simultaneous processing with upper, middle and lower servo sliding tables

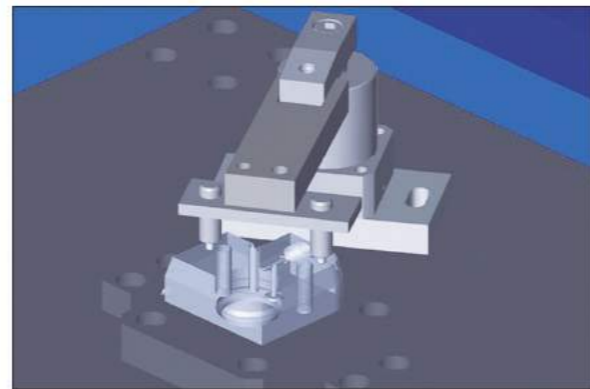

LVDT檢測工件孔的深度
LVDT detecting the depth of workpiece hole



6工位CNC多軸轉盤加工機

6 Stations CNC Horizontal Rotary Transfer Machine

特色：

- * 採用精密主軸頭
- * 大量生產零件之最佳機種
- * 機台結構簡單，穩定性高，維修保養容易

Feature :

- * Using the precision spindle
- * Optimal model for handling the production of massive parts
- * Simple machine structure. Higher in stability and easier for maintenance and daily service

加工範例

工件：鋁環
材質：鋁

Process Example

Workpiece : Aluminum Ring
Material : Aluminum



視覺檢測系統

Vision inspection system



	上 Up	側 Side	下 Down
1	上料：自動 / 下料：自動 Loading : Auto / Unloading : Auto		
2		鑽孔 Drilling	
3		鑽孔 Drilling	
4		鑽孔 Drilling	
5		攻牙 Tapping	
6		刮溝 Sawing the Groove	



6工位10軸轉盤加工機

6 Stations 10 Spindles Horizontal Rotary Transfer Machine

特色：

- * 產能比油壓水車多出1倍
- * 一台抵10台 CNC加工中心機
- * 特殊夾具設計，穩固異型工件之夾持

Feature :

- * Double productivity compared to the hydraulic trunnion rotary transfer machine
- * A machine can replace TEN cnc rotary machining center
- * Unique jig design and steadily clamp the special shape workpiece

加工範例

工件：汽車搖臂
材質：鑄鐵

Process Example

Workpiece : Rocker
Material : Cast-iron

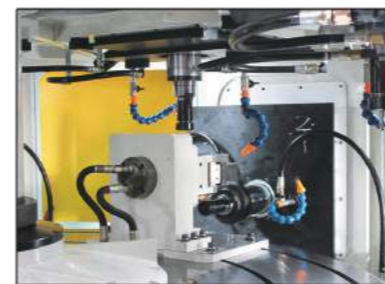

異形工件，同時進行加工

Special shape workpieces process at the same time



	上 Up	側 Side	下 Down
1	上料：自動 / 下料：自動 Loading : Auto / Unloading : Auto		
2	粗鑽孔+平面粗車 Rough Boring + Rough End Face Milling		中心鑽孔 Center Drill
3	銑圓弧 Circular Arc Milling		鑽孔 Drilling
4	銑圓弧 Circular Arc Milling		鑽孔 Drilling
5	精鑽孔+平面精車+倒角 Precious Boring + Precious End Face Milling + Chamfering		攻牙 Tapping
6	鑄鋼溝槽 Saw Grooving		

9工位CNC多軸轉盤加工機 9 Stations CNC Horizontal Rotary Transfer Machine

- 特色:**
- * 對話式操作畫面，容易設定參數
 - * 快速換模(Zero Print)治具，大幅縮短工件換線時間
 - * 預設保留孔(讓客人未來可加裝主軸)
- Feature:**
- * Conversational operation screen, easy to set parameter
 - * Quickly replace the modular jig (Zero Print) and significantly reduce the time for changing the workpiece
 - * The machine presets the reserved hole in the future
- 加工範例**
工件: 閥類
材質: 鋁合金、銅合金
- Process Example**
Workpiece: Valve
Material: Aluminum Alloy
、 Brass Alloy



	上 Up	側 Side	下 Down
	上料: 自動 / 下料: 自動 Loading: Auto / Unloading: Auto		
1			銑側面平面 Milling the Side Surface
2			鑽孔 Drilling
3	鑽孔 Drilling		
4			
5			
6		攻牙 Tapping	
7	轉向 Recurvature	轉向 Recurvature	
8		斜孔 Inclined Hole	
9	攻牙 Tapping	攻牙 Tapping	攻牙 Tapping

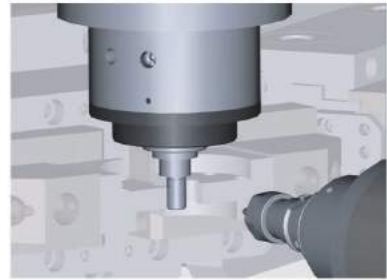

筒夾機構
Collet mechanism

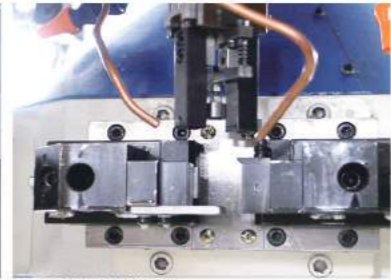

工件旋轉機構(180°)
Turn over the workpiece mechanism(180°)

9工位19軸轉盤加工機 9 Stations 19 Spindles Horizontal Rotary Transfer Machine

- 特色:**
- * 同步加工三路
 - * 此設備擁有特殊形狀加工
- Feature:**
- * This machine is processing synchronously for three ways
 - * The equipment for many functions such as processing special shapes, etc
- 加工範例**
工件: 潔浴設備
材質: 黃銅
- Process Example**
Workpiece: Bathroom Equipment
Material: Brass



	上 Up	側 Side	下 Down
	上料: 自動 / 下料: 自動 Loading: Auto / Unloading: Auto		
1			
2	粗鑽孔 Roughly Boring	粗鑽孔 Roughly Boring	粗鑽孔 Roughly Boring
3	精鑽孔 Precisely Boring	精鑽孔 Precisely Boring	精鑽孔 Precisely Boring
4	鑽孔+攻牙 Drilling and Tapping		攻牙 Tapping
5		鑽孔 Drilling	
6	鑽孔+中心鑽 Drilling and Center Drill	鑽孔 Drilling	
7	鑽孔 Drilling		銑圓溝 Milling Round Groove
8		銑左斜孔 Drilling the Left Tilted Hole	
9	攻牙 Tapping	攻牙 Tapping	銑凹槽 Milling the Filler



伺服控制傾斜主軸
Servo control the spindle tilt



三方向主軸
Tri-direction spindles

12工位CNC多軸轉盤加工機 12 Station CNC Horizontal Rotary Transfer Machine

- 特色:**
- * 車床結合CNC多軸加工機
 - * 搭配自動送下料、全伺服控制
- Feature:**
- * Lathe machine combined with the cnc multi-spindles transfer machine
 - * With automatic loading/unloading and fully servo control
- 加工範例**
工件: 手工工具、管件
材質: 鋼
- Process Example**
Workpiece: Hand Tool、Fitting
Material: Steel

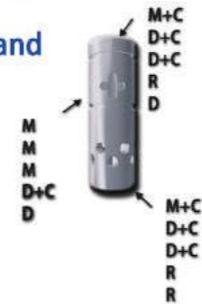

	上 Up	側 Side	下 Down
	上料: 自動 / 下料: 自動 Loading: Auto / Unloading: Auto		
1			銑端面+倒角 Milling and Chamfering
2			
3	銑端面+倒角 Milling and Chamfering	粗銑槽 Rough Milling the Long Groove	鑽孔+倒角 Drilling and Chamfering
4	鑽孔+銑端面 Drilling and Chamfering	精銑槽 Precision Milling the Long Groove	鑽孔+銑端面 Drilling and Chamfering
5	鑽孔+銑端面 Drilling and Chamfering		鑽孔+銑端面 Drilling and Chamfering
6	展外溝槽 Boreing the Outer Groove		展內溝槽 Recessing the Inner Groove
7	旋轉刮刀 Coolant Through Spindle		中心出水 Coolant Through Spindle
8	旋轉刮刀 Coolant Through Spindle		旋轉刮刀 Coolant Through Spindle
9		精十字槽 Precision Milling the Cross Groove	
10	位移主軸 Displacement Spindle	鑽孔+倒角 Drilling and Chamfering	
11			展內溝槽 Recessing the Inner Groove
12	去毛刺 Deburring	去毛刺 Deburring	

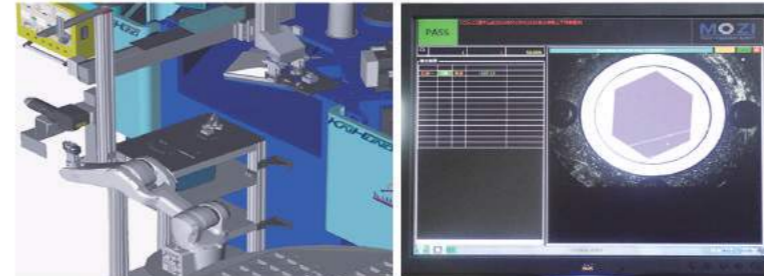

多軸機械手與伺服滑台合作，利用CCD視覺指揮機械手夾取工件，結合雷雕機。在工件加工前打刻序號
Articulated manipulator and servo screw actuator are cooperation. Applying the CCD vision conducts to clamp the workpiece and laser engraving which making the serial number on the workpiece before the workpiece processing.

12工位17軸轉盤加工機 12 Station 17 Spindles Horizontal Rotary Transfer Machine

- 特色:**
- * 精度要求高，位置度公差控制在±0.02mm
 - * 考慮高硬度材質，設計合適的加工方式
- Feature:**
- * High precision request that to position tolerance is ±0.02mm
 - * The machine applies to high hardness material
- 加工範例**
工件: 連結塊
材質: 高強度鋁合金
- Process Example**
Workpiece: Joint Block
Material: High Strength Aluminum Alloy

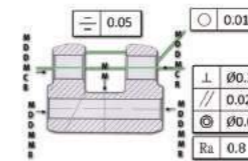

	上 Up	側 Side	下 Down
	上料: 自動 / 下料: 自動 Loading: Auto / Unloading: Auto		
1			銑端面 Milling Surface
2	銑端面 Milling Surface		銑端面 Milling Surface
3	打中心孔 Center Drilling	粗銑槽 Roughly Milling Center Groove	打中心孔 Center Drilling
4	鑽孔 Drilling		鑽孔 Drilling
5	鑽孔 Drilling		鑽孔 Drilling
6	銑孔 Milling		
7	銑孔 Milling		
8	銑孔 Milling	精銑槽 Precisely Milling Center Groove	
9	銑孔 Milling		
10	內側銑槽 Inside Chamfer: Upper Hole		
11	銑孔 Reaming		
12	銑孔 Reaming		



二軸向伺服機械手
Two-axis servo manipulator



CNC水車多軸加工機 CNC Multi-spindles Trunnion Rotary Transfer Machine

水車多軸加工機為“立式轉盤”，針對三方向以中心孔加工的設備。每一軸以對話式程式編輯，可做搪孔、攻牙、溝槽等功能。

The multi-spindles rotary transfer is "Trunnion Rotary" which is specially designed for the machining of tri-direction center holes. Each spindle is provided with dialogue-type program editing function to carry out boring, tapping and groove cutting functions.



加工範例
工件：截止閥
材質：黃銅

Process Example
Workpiece : Cut-out Valve
Material : Brass

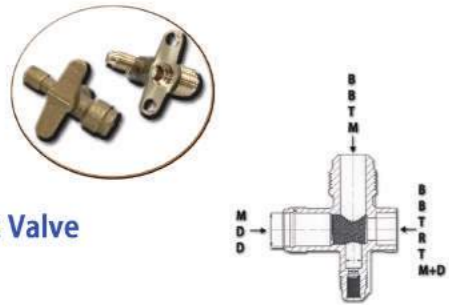

6 工位 6 軸水車加工機 6 Stations 6 Spindles Trunnion Rotary Transfer Machine

特色：
* 配置十字滑台，主軸可進行三方向位移
* 依工件尺寸選備不同大小的主軸頭
* 自動送下料

Feature :
* Fitted with cross-type slide table for the spindle to perform tri-directional displacement
* Varied size of spindles can be selected according to the dimensions of the workpiece
* Automatic loading and unloading

加工範例
工件：煞車系統
材質：碳鋼、銅

Process Example
Workpiece : Brake System
Material : Carbon Steel、Copper



油孔尺寸位置檢知
Detecting for the oil hole's size and position

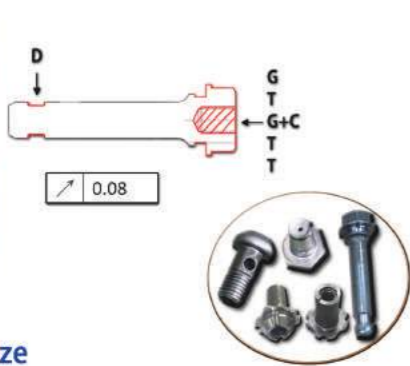

左 Left	中 Middle	右 Right
	上料：自動 / 下料：自動 Loading : Auto / Unloading : Auto	
1 中心鑽 Center Drill		車溝槽 Grooving
2		粗車端面 Rough End Face Turning
3		車溝槽+倒角 Grooving and Chamfering
4		精車端面 Precisely End Face Turning
5		攻牙(無屑攻牙) Tapping (Chipless Tapping)
6		

8 工位CNC多軸水車加工機 8 Stations CNC Trunnion Rotary Transfer Machine

特色：
* 預設保留孔
* 配置十字滑台
* 依工件尺寸選備不同大小的主軸頭

Feature :
* The machine presets the reserved hole in the future
* Fitted with cross-type slide table
* Varied size of spindles can be selected according to the dimensions of the workpiece

加工範例
工件：逆止閥
材質：黃銅

Process Example
Workpiece : Check Valve
Material : Brass

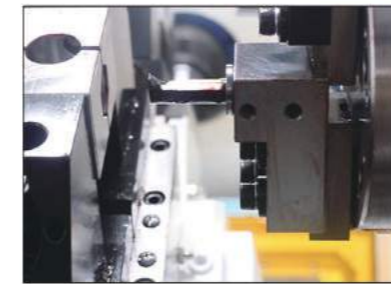

車 8° 斜面、車圓弧 R87.5
Turning 8° bevel、
Turning the arc R87.5

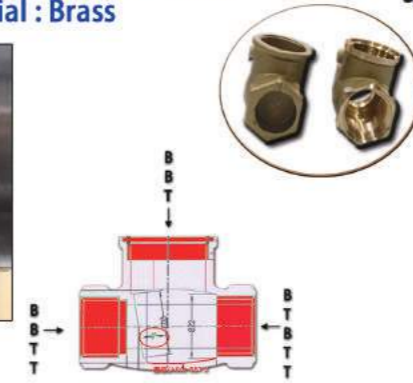

左 Left	中 Middle	右 Right
	上料：自動 / 下料：自動 Loading : Auto / Unloading : Auto	
1	保留孔 Reserved Hole	粗搪孔 Roughly Boring
2		精搪孔 Precisely Boring
3	粗車圓弧 Roughly Turning the Arc R87.5	粗搪孔 Roughly Boring
4	精搪孔 Precisely Boring	車 8° 斜面 Turning 8° Bevel
5	精車圓弧 Roughly Turning the Arc R87.5	保留孔 Reserved Hole
6	攻牙 Tapping	精搪孔 Precisely Boring
7		攻牙 Tapping
8		攻牙 Tapping

8 工位 9 軸水車加工機 8 Stations 9 Spindles Trunnion Rotary Transfer Machine

特色：
* 依據工件規劃工位、主軸數目
* 位移方向可伺服控制，提供整體生產效能

Feature :
* Based on workpiece to project the quantity of stations and spindles
* The direction of displacement can be servo controlling
* Improve entire production efficiency

加工範例
工件：引擎零件
材質：碳鋼

Process Example
Workpiece : Engine Parts
Material : Carbon Steel



治具定位缸
Fix position cylinder for jig

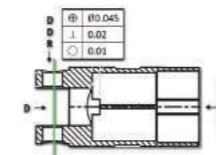

左 Left	中 Middle	右 Right
	上料(配治具定位缸)：自動 / 下料：自動 Loading (with Fix Position Cylinder for Jig) : Auto / Unloading : Auto	
1	粗鉗孔 Roughly Drilling	粗鉗孔(第一次) Roughly Drilling
2		粗鉗孔(第二次) Roughly Drilling
3	精鉗孔 Precisely Reaming	粗鉗孔(第一次) Roughly Drilling
4		粗鉗孔(第二次) Roughly Drilling
5	內側去毛刺 Insides Deburring	銹底面 Milling the Bottom Surface
6		精鉗孔 Precisely Reaming
7		
8		精鉗孔 Precisely Reaming



馬達總組立線與測試線 Assembly Line and Testing Line



粉塵清潔
Dust cleaning the stator and the internal body



置入波形墊圈
Place in wave washer

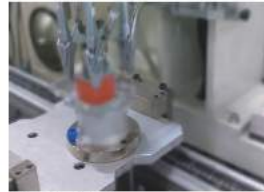

自動螺絲站
Automatic screw tightening station

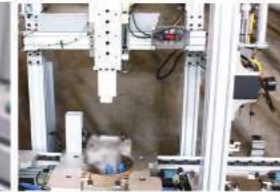

檢測軸向間隙長度
Testing axial clearance length



檢測三相電壓端子
Testing three-phase voltage terminal



檢測扭力值
Inspect screw tighten torque



使用條碼分辨料號
Using the bar code to distinguish workpiece



全行程監控伺服壓床 Full-process Monitor Servo Assembling Press Machine



壓力曲線
Pressure curve

特色:

- * 1T,3T,5T
- * 全行程監控適合精密壓配
- * 壓入行程可自行設定
- * 由壓力檢知器讀得每一尺寸壓力值，轉換成壓力曲線，並可每日、每週、每月做紀錄

Feature :

- * 1T,3T,5T
- * Full-process monitor apply to press and assembling precisely
- * It can set the process of pressing in manually
- * Read each dimension of pressure value by load cell, transfer to pressure curve, and it can be recorded by daily, weekly, monthly



自動化生產組立線 Automatic Assembly Line



全自動軸鐵芯熱合測試組立機 Automatic Rotor of Shaft and Lamination Assembly Machine



高週波機加熱鐵芯
High frequency heating lamination

矽鋼片厚度檢測
Lamination thickness detection

軸芯脫拔力測試
Shaft pull-off tester

偏擺測試機
Run-out test

全自動鐵心塗膠磁鐵組合機 Automatic Rotor Magnet Gluing and Assembly Machine



塗膠
Glue instillation

組入磁鐵
Magnet fitting

組入扣環
Circlip press fit by robot

多關節機械手協同合作
Two manipulators are cooperation

轉子組入機 Pressing Machine by Servo Controller



雷射感測器
Laser sensor

定子組入機 Stator & Motor Case Press Fit Machine



機種配對(條碼掃描)
Workpiece pairing by using barcode



精密組裝室
Precision Assembly Workshop
 配備空調設施，穩定主軸組裝精度
 The shop equips with air conditioner to keep precision of spindles assembling



精密測量室
Precision Measuring Machine
 嚴密精準的量測設備，確保品質
 Precision measuring equipment ensures 3D mechanical quality



研究開發部
Research & Development Department
 運用SolidWorks 3D CAD 軟體，提高機台嚴謹度
 We use SolidWorks 3D CAD software to raise the accuracy of machine



工作區妥善的製程安排
Work Area Appropriately Arrange Production Project

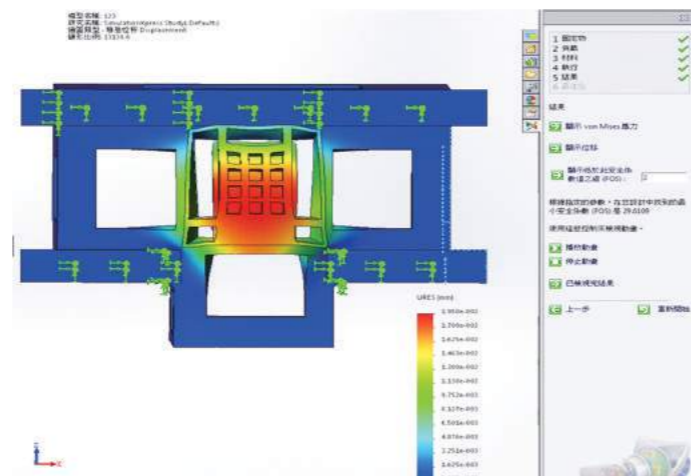

加工實例
Processing Examples



電子接頭
Electronic Connectors



熱水氣管接頭
Water Pipe Joints



水錶頭
Water Meter



水龍頭
Faucet



各銅類零件
All Parts of Brass



不鏽鋼接頭
Stainless Steel Fitting



鋁壓鑄外殼
Aluminum Die Casting



鎖頭
Lock



鋁鍛件、鋁擠型、腳踏車
Aluminum Forgings, Aluminum Extrusion, Bicycle



鋁鋅鑄件、馬達殼、汽配零件
Aluminum and Zinc Castings, Motor Housings, Auto Parts



汽機車零件
Automobile Parts



空壓、電磁閥零件
Pneumatic Solenoid Valve Parts